



# Knock **OFF**

Official Publication of the Mohawk-Hudson Region



Mohawk-Hudson Region SCCA

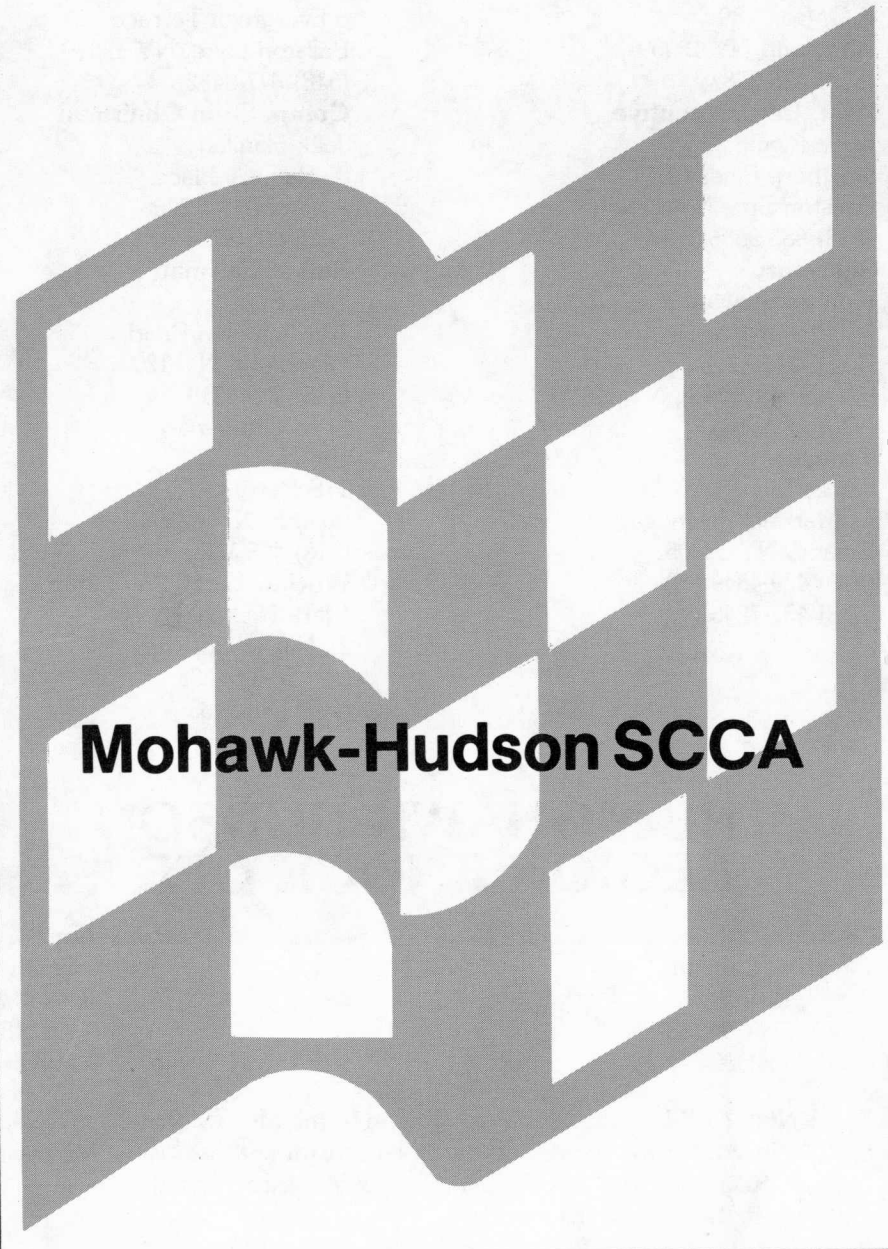

## Mohawk-Hudson SCCA

March 1988



# Knock **OFF**

Official Publication of the Mohawk-Hudson Region

P.O. Box 170  
Watervliet, N.Y. 12189

Clark Nicholls  
21 Hartwood Rd.  
Lee, MA 01238



# MOHAWK-HUDSON REGION OFFICERS — 1988

## Regional Executive

John C. Sheridan  
P.O. Box 739  
Altamont, NY 12009  
(518) 456-7787

## Asst. Reg. Executive

Dave Riggi  
Northern Pines Pk.  
Ballston Spa, NY 12020  
(518) 885-9656

## Secretary

Richard Stewart  
6 Fletcher Place  
Box 160  
West Sand Lake, NY 12196  
(518) 674-5683

## Treasurer

James Bishop  
41 Marriner Avenue  
Albany, NY 12205  
(518) 489-4849 (H)  
(518) 457-7245 (W)

## Membership Chairman

Michael Weir  
6 Evergreen Terrace  
Ballston Lake, NY 12019  
(518) 877-8482

## Competition Chairman

Jack Hanifan  
39 Ramsey Place  
Albany, NY 12208  
(518) 438-3754

## Rally Chairman

John Stim  
103 Jefferson Road  
Glenmont, NY 12077  
(518) 439-0319

## Solo Chairman

Jim Garry  
11B Barry Ct.  
Selkirk, NY 12158  
(518) 475-1629

## Worker Licensing Chairm

Clark Nicholls  
21 Hartwood Road  
Lee, MA 01238  
(413) 243-3433

## THE MOHAWK-HUDSON REGION KNOCK-OFF

### Editor

David McClumpha  
Rte. 3, Box 21  
Selkirk, NY 12158  
(518) 767-2308

### Publisher

George Smith  
Rte. 3, Box 153  
Troy, NY 12180  
(518) 279-3356

The KNOCK-OFF is the official publication of the Mohawk-Hudson Region, SCCA, Inc. Opinions expressed are not necessarily those of the Mohawk-Hudson Region or the Sports Car Club of America. The deadline for all materials is the **15th** of the month.



# Altamont Sports Canopy

We've got You Covered

Authorized Distributor/Dealer for **Pit Master**  
Sport Canopies manufactured by A & L Products®

Inquire about  
our "club discounts"

Here are two of our many styles

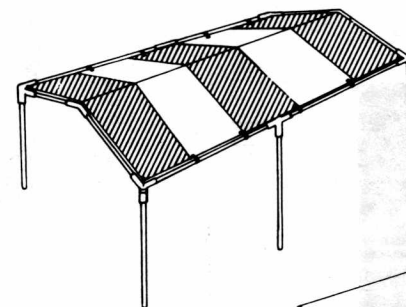

### TRIMLINE™

Prices for kit with  
Poly Tarp start at just **\$129.00**  
Prices for kit with  
Vinyl Tarp start at just **\$189.00**

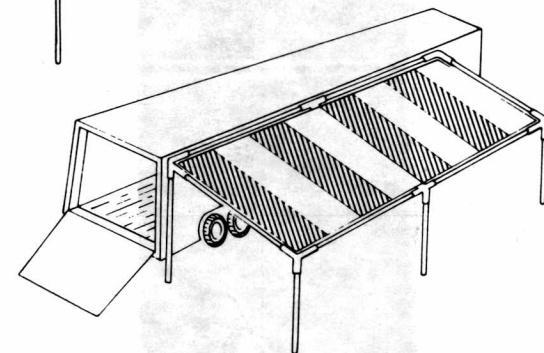

### CABANA™

Prices for Kit with  
Poly Tarp start at just  
**\$99.00**  
Prices for Kit with  
Vinyl Tarp start at just  
**\$159.00**

Kits include all parts needed except tubing

*Poly Tarps are blue — Vinyl Tarps are available in a choice of colors or combinations*

You can customize your canopy with matching solid vinyl walls, window walls, screen walls, built in tables and flag holders. For the Professional Team look we offer custom Graphics by KT Motorsports. Imagine your canopy in your colors with your team or sponsors name and logo proudly displayed.

**For information and prices contact John Sheridan**



**(518) 456-7787**

Dealer Inquiries Invited



**Altamont Sports Canopy** P.O. Box 705 Altamont, N.Y. 12009

# DRAGONSLAYER, INC.

YOUR SAFETY IS OUR BUSINESS!

**GREAT GIFT IDEAS**

## Safety Equipment

**DISCOUNT SAVINGS !**

**Driving Uniforms**  
Including the exciting Proline.



**Accessories**  
Gloves, shoes, crew uniforms,  
seat belts and harnesses, and more!



**Bell Helmets**



**Gift Certificates**  
Can't decide on a gift? Gift certificates are available in any denomination. Call for information.

**CHARGE IT**

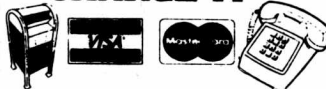

**FIREBOTTLE**

Halon Fire Suppression System



Dealer Inquiries Invited

**CREW UNIFORMS:**

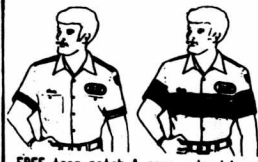

FREE team patch & name embroidery.



**Harnesses**

Complete line of driver restraints



February 19, 1988

Costa J. Dunias  
Vice President, Club Affairs  
Sports Car Club of America, Inc.  
P.O. Box 3278  
Englewood, CO 80112-2105

Dear Costa:

On behalf of the Board of Directors of the Mohawk-Hudson Region, I am writing to express our displeasure with the increase in club racing sanction fees recently approved by the National Board of Directors.

If the fees had simply been increased to \$250 for Regional Races and \$500 for National Events, we would not be displeased. We are realistic and recognize that everyone's costs have increased over the years. Our concern, however, is with the \$5 per car surcharge for every car over 150 entrants. Last year our one and only regional race drew over 280 entries. Under the new fee schedule, we would have had a race sanction fee of over \$900. We cannot believe that the sanction fee for our race should be more than three times that of another regional race with only 150 entries.

The services cited as justification for the new fee structure are for the most part independent of the number of race entries. There is no acceptable reason, therefore, for linking these in the manner proposed.

We strongly urge the Board of Directors to repeal the surcharge portion of the new sanction fee schedule. If the new flat rate is not sufficient to cover the increased costs associated with sanctioning fees, then perhaps a higher flat rate is in order. We consider the surcharge plan to be excessive and unjustifiable.

Respectfully,

*John C. Sheridan*  
John C. Sheridan  
Regional Executive

439  
3107

bjp

xc: John Castle, Director Area 10  
Editor, "Sports Car"

DRAGONSLAYER, INC.  
826 PINWOOD AVE. SCHENECTADY, N.Y. 12309  
(Mail & Phone Orders only)  
[518] 382-0978



Mohawk-Hudson Region SCCA

**MINUTES OF THE FEBRUARY 3, 1988 MEMBERSHIP MEETING**

Meeting called to order by R.E. John Sheridan at 7:38 PM. There were 21 members and 1 guest present.

Secretaries report, has been published in the **KNOCK-OFF**, but not available at the meeting - I apologize for this oversight.

**Executive Board Meeting** report was given by R.E. John Sheridan and will appear in the next **KNOCK-OFF** issue. John did inform the members present that the Preseason Tech Inspection may have to be cancelled. Also our March Membership Meeting will be Auction Night with Honest Harold Cameron as auctioneer.

**Treasurers' Report by Jim Bishop** - Jim is looking into the possibility of higher interest rates in our savings account and will report on this at our next meeting motion made by Tom Campbell and seconded by Bob Daly to accept the report - motion carried.

**Rally Report by Jim Bishop** - Jim reported Thom and Shawn O'Connor will be making a serious effort to run at Pike's Peak. If you could help them in anyway I'm sure they would appreciate it. Also, Thom has recently become the New York Rally Steward - Congratulations, Thom!

**Snowflake Rally** to be held on February 20, 1988 at 5:30 PM. Starting point will be the Stardust Motel, The Rally will be sponsored by KT Motor Sports and NOKIA Tires Arthritis Rally is scheduled for April 10th - more information to appear in this **KNOCK-OFF**.

**Solo Report** - given by John Sheridan in the absence of Jim Gary. John reported Jim needs some assistance checking on a reported 12 lots that could be available for Rallies. If you are interested please contact Jim Gary.

**Membership Report** given by Mike Weir - Mike reports we again have several new members and even better, they are asking questions about race cars.

continued.../2



A008



A001R



352

**IKC**  **YOKOHAMA**

**motorsports**

**CALL NOW!**

po box 152  
voorheesville, ny  
12186

**FOR BEST PRICES ON  
SELECTION  
OUR FULL**



**518 765 2206**



**AUTOMOTIVE INC.**  
 60 Fourth Avenue  
 Albany, New York  
 436-3555

## WE'VE MOVED!

Note our new address and new phone number

## We're Growing

Our new, modern, computerized 7,200 square foot facility on Fourth Avenue will offer:

- Faster Service
- Increased Staff
- Ample Parking
- Enhanced Quality Control
- Larger Shop Area
- Spacious - Efficient Counter Area
- Easier Drop Off and Pick Up

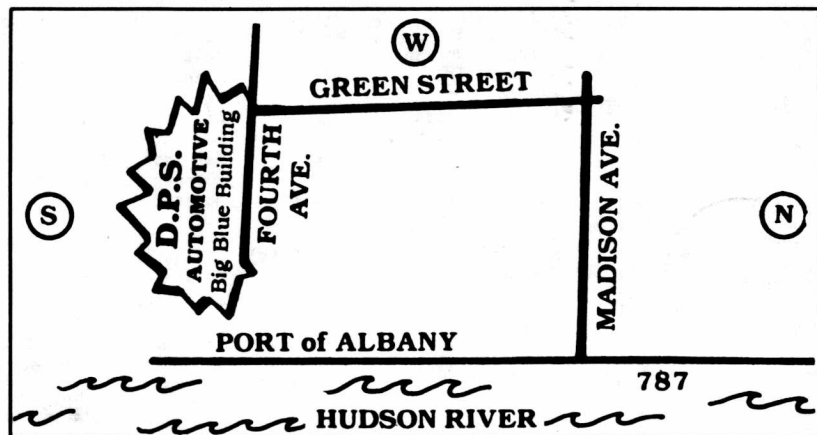

**"WE REBUILD ENGINES"**

Specializing in Foreign and Domestic Engine Parts

### Minutes of the February 3, 1988 Membership Meeting (continued)

**Old Business** - NARRC Banquet being organized by Lee Schailer. Fliers will be sent out soon. NARRC final standings have been published and John Sheridan has them. John Sheridan has recently received more questions on the Silvermines 85 race accident and will answer what he can and sending it back.

#### - New Business -

- Nediv Round Table coming up in March more information to follow in the **KNOCK-OFF**.
  - NARRC rules for 88 may include a sponsorship package from Bridgestone Tires in several classes. There was much discussion on this type of a program in Regional racing and the majority at the meeting were not in favor of this program. There will be more information on this in the **KNOCK-OFF**.
  - Also, up for serious discussion is the NARRC procedure for picking their champions.
  - Tom Campbell will be putting together a copy of the Mohawk Hudson By-Laws these will soon be available.
  - Jim Bishop read the proposed Budget for 88.
  - Jim Bishop and Ernie Riggi had a very good discussion on the advantages of computers in racing results and registration.
  - Mike Weir and Ernie Riggi volunteered together more information on the computers and will try to report at the April meeting.
  - March 5th is the Area 10 meeting in Syracuse, John Sheridan and Dave Riggi will be attending. Motion was made by Jack Hanifan and seconded by Roly Heacox to pay for their registration fee and expenses not to exceed \$200.00. Motion was carried.
  - The NEDIN Round Table coming up and a motion made by Jack Hanifan seconded by Roly Heacox to allow up to \$45.00 for each of our members attending up to 10 members - motion was carried. These members must come back with a report for the April meeting.
  - Dave Riggi will contact the Ramada Inn to see what refreshments may be available on meeting nights and also the possibility of a Horseshoe shape table set up for meetings.
- Dave McClumpha has the Regions' Mimeograph machine and will be accepting bids on this equipment. If you are interested in this equipment, please contact John Sheridan or Dave Riggi.
- Motion was made by Dave McClumpha, seconded by Ernie Riggi to adjourn. Motion carried.
- Hope to see you at the next meeting March 2, 1988.

Respectfully submitted  
 Dick Stewart

DS/sh



To: The Individuals Listed Below  
 From: JCS, Regional Executive  
 Date: February 19, 1988  
 Sub: Starton vs. SCCA

Please be advised that your name, address, and phone number have been provided to Lawrence R. Pellett who is representing us in the above referenced lawsuit. Mr. Pellett has requested the names of certain individuals who acted in an official capacity at the 1985 Silver Mines Regional:

- Roland Heacox
- Harold Cameron
- David Zabel
- Robert Burns
- Eric Weiss

J.C.S.

bjp

xc: "Knock Off"

(t) year-end trophy winner

1987 NYSRRC FINAL POINT STANDINGS

<u>SSGT</u>		<u>ITC</u>		<u>GP</u>	
*Snedeker, C.J.	77 (t)	Corbett, John	69 (t)	Payne, John	100 (t)
Tupper, Kim	52 (t)			Killeen, Mike	68 (t)
Shaw, Gary	50	<u>GT1</u>		Rynone, Bob	55
<u>SSA</u>		Bridgette, Richard	94 (t)	<u>HP</u>	
deCordre, Spencer	104 (t)	Welding, Clint	65 (t)	Brown, Jim	180 (t)
Leitzenger, Butch	89	Emery, Doug	65 (t)	Collishaw, Dan	63 (t)
<u>SSB</u>		Kelley, Phil	50 (t)	Ebersbach, Jim	27 (t)
Alaimo, Gerald	169 (t)	Brothers, W. Scott	49 (t)	Connor, Carolyn	26
Toth, Andrew	63 (t)	Badura, Bob	34	LeFond, Debra	18
Henderson, J. Robert	60 (t)	Houseworth, Dave	14	<u>ASR</u>	none
Abraham, Mark	46 (t)	<u>GT2</u>		<u>CSR</u>	none
Hartman, Mary K.	26 (t)	Bauer, Keith	62 (t)	<u>DSR</u>	none
McCoy, Diane	10	Limbert, Steve	60 (t)	<u>S-2000</u>	none
Hanifan, Jack	5	Cavallo, Mary Jo	31	<u>F-Atlantic</u>	none
<u>SSC</u>		<u>GT3</u>		<u>F-Continental</u>	
Weeks, Paul	139 (t)	Fell, Dick	70 (t)	Smith, Ron	64 (t)
Meyer, Dave	84 (t)	Smith, Alex	23	Brown, Gerald	52 (t)
Llewellyn, R.L.	32	<u>GT4</u>		Gee, Tom	37
<u>ITS</u>		English, Dave	21 (t)	<u>Club Ford</u>	
Hasenkamp, Barnd	87 (t)	<u>GT5</u>	none	Fay, Ken	154 (t)
Mischler, Jim	75 (t)	<u>Sports Renault</u>		Dean, Breck	112 (t)
Hilgers, Klaus	40	Pluta, Wayne	109 (t)	Black, Gregory	25* (t)
<u>ITE</u>	none	Cronin, Ed	60 (t)	Mack, Bill	24
<u>ITA</u>		Morse, Bill	62 (t)	Bonnier, Mat	12
Foster, Bill	133 (t)	Bell, Louie	57 (t)	<u>FF</u>	
Kiceniuk, Richard	85 (t)	Ferrara, Dennis	35 (t)	Coons, Michael	105* (t)
Plummer, Dave	56 (t)	Henderson, Phil	34 (t)	Kassel, Barry	76 (t)
Strate, Russell	56 (t)	Swanson, Randy	24	Kassel, Ahnen	75 (t)
Formack, David	41 (t)	Newsome, Bob	21	Pyanowski, Chuck	54 (t)
Caldwell, Don	41 (t)	Borczone, Norman	13	Wright, Brad	52 (t)
Mina, Steve	33	Stevens, Thom	11	Civiletto, Dave	45 (t)
Korinis, Andy	28	Watson, Cliff	10	Graham, Joby	39
Levin, Mike	12	Mitchko, Linda	10	Marcinski, Joe	25
Mosher, Dick	7	Scarborough, Mark	7	Klinger, Grant	15
<u>ITB</u>		Jaslow, Russell	6	Morford, Bob	2
Hunt, Phil	92 (t)	Price, Gary	5	<u>F-440</u>	
Weaver, John	74 (t)	Lasda, Sheldon	4	Shaughnessy, Tom	94 (t)
Britton, Gary	70 (t)	<u>EP</u>		Goodman, Robert	54 (t)
Ryder, Bruce	61 (t)	Maciolek, Bill	68 (t)	Staffiero, Nick	44
Kraus, Johannes	55 (t)	Kreuger, Eric	35		
Boswell, Bill	50 (t)	<u>FP</u>			
Nelson, Jack	39	Smith, Pete	110 (t)		
McAllister, Mark	32	Young, Burt	82 (t)		
Palmerton, Dan	30	Robinson, Colin	22		
Haines, Jeff	21				
Quigg, Roger	14				
Hyatt, Stephen	5				
Meyer, Bill	4				

( OVER )



Mohawk-Hudson Region SCCA

PITTSFIELD WINTER SPORTS COMMITTEE  
MOHAWK HUDSON REGION SCCA  
BERKSHIRE MOTOR SPORTS CLUB

28th ANNUAL ICE TRIALS - 2-7-88 - OFFICIAL RESULTS  
SUNDAY

T NEXT TO POSITION INDICATES A TROPHY WAS AWARDED  
B NEXT TO TIME INDICATES BEST TIME  
FTD NEXT TO POSITION INDICATES FASTEST TIME OF DAY  
D N F INDICATES DID NOT FINISH, PROBABLY BECAME STUCK  
D N R INDICATES DID NOT RUN

(4WD) FOUR WHEEL DRIVE UN-STUDDERED CLASS - SUNDAY 2-7-1988

* NAME	*NUMB*	CAR	* RUN 1 *	* RUN 2 *	* RUN 3 *	* RUN 4 *	* RUN 5 *	*POS*
DON WECHTER	7	TOYOTA PICKUP	1:49.24	B1:45.19	1:47.32	1:45.52	D N R	* 1T
MIKE CAROPRESSO	41	TOYOTA PICKUP	B1:47.86	D N R	D N R	D N R	D N R	* 2T
BRUCE TAYLOR	16	SUZUKI SAMURAI	1:54.19	B1:48.63	1:51.84	1:48.95	1:51.55	* 3
WILLY HAYES	10	SUZUKI	1:53.76	1:50.18	1:50.96	1:52.07	B1:49.59	* 4
MICKEY FINN	43	FORD BRONCO	2:12.23	B1:52.49	D N R	D N R	D N R	* 5

(FRS) FRONT ENGINE REAR DRIVE STUDDERED CLASS - SUNDAY 2-7-1988

* NAME	*NUMB*	CAR	* RUN 1 *	* RUN 2 *	* RUN 3 *	* RUN 4 *	* RUN 5 *	*POS*
GERARD MICHNEY	31	MAZDA 626	1:48.68	1:49.56	2:28.53	B1:48.07	D N R	* 1T
BILL FOSHAY	5	MAZDA 626	D N F	1:53.36	1:54.09	B1:50.79	1:56.24	* 2
THERESA TERRY	29	MAZDA 626	1:59.70	B1:54.08	1:54.96	D N R	D N R	* 3

(FRM) FRONT ENGINE REAR DRIVE SHEET METAL SCREWS - SUNDAY 2-7-1988

* NAME	*NUMB*	CAR	* RUN 1 *	* RUN 2 *	* RUN 3 *	* RUN 4 *	* RUN 5 *	*POS*
CHRIS HAVAS	14	MERCURY CAPRI	1:39.52	B1:35.57	D N F	1:39.58	* 1T	
RAY BOWDEN	19	MERCURY CAPRI	B1:38.29	1:49.62	D N F	D N F	* 2T	
KARL FRANTZ	23	MERCURY CAPRI	1:45.68	1:42.73	1:42.69	D N F	* 3	
BERNIE MALUMPHY	22	BUICK STOCKCAR	B1:47.38	2:04.29	1:50.09	D N R	* 4	
GARY VIRGLIO	34	BUICK STOCKCAR	B1:59.78	2:10.48	D N R	D N R	* 5	

(FF) FRONT ENGINE FRONT DRIVE UNSTUDDERED CLASS - SUNDAY 2-7-1988

* NAME	*NUMB*	CAR	* RUN 1 *	* RUN 2 *	* RUN 3 *	* RUN 4 *	* RUN 5 *	*POS*
KEITH MARTENS	11	CHEVY CITATION	B1:44.59	1:45.26	1:45.62	1:45.22	* 1	
STEVE SPRAGUE	25	SAAB 900	B1:48.01	D N R	D N R	D N R	* 2	

(RRS) REAR ENGINE REAR DRIVE STUDDERED CLASS - SUNDAY 2-7-1988

* NAME	*NUMB*	CAR	* RUN 1 *	* RUN 2 *	* RUN 3 *	* RUN 4 *	* RUN 5 *	*POS*
FRED SCOTT-SMITH	32	FIAT X-1/9	B1:26.40	1:27.46	1:34.30	1:31.00	* 1-FTD	
BRIAN BURBANK	37	FIAT X-1/9	D N F	B1:36.89	1:42.40	1:57.42	* 2	

(DB) REAR ENGINE, REAR DRIVE, STUDDERED DUNE BUGGY CLASS - SUNDAY 2-7-1988

* NAME	*NUMB*	CAR	* RUN 1 *	* RUN 2 *	* RUN 3 *	* RUN 4 *	* RUN 5 *	*POS*
GEORGE GOODRICH	20	DUNE BUGGY	1:34.04	1:39.16	1:33.93	B1:32.48	* 1T	
JIM MCDERMOTT	40	DUNE BUGGY	1:44.54	1:35.03	1:35.54	B1:33.46	* 2T	
BILL GOODRICH	26	DUNE BUGGY	1:40.16	1:36.29	B1:35.37	1:35.77	* 3	
KEITH COOPER	13	DUNE BUGGY	1:39.35	B1:36.67	1:39.43	1:41.10	* 4	
KEITH S COOPER	28	DUNE BUGGY	2:16.64	B2:07.73	D N R	D N R	* 5	

(FFS) FRONT ENGINE FRONT DRIVE STUDDERED CLASS - SUNDAY 2-7-1988

* NAME	*NUMB*	CAR	* RUN 1 *	* RUN 2 *	* RUN 3 *	* RUN 4 *	* RUN 5 *	*POS*	
BOB CLAFFIE	17	HONDA CIVIC	1:29.82	1:29.69	1:29.38	B1:29.04	D N R	* 1T	
WILSON WRIGHT	4	VW RABBIT	B1:31.78	1:33.14	1:39.74	1:32.41	D N R	* 2T	
LARRY SNYDER	44	SAAB 96	1:38.14	1:37.09	1:38.14	1:43.62	B1:36.87	* 3T	
ALAN CLAFFIE	2	HONDA CIVIC	1:38.84	B1:36.92	1:37.06	1:39.28	D N R	* 4	
DAN GILMORE	8	FORD FIESTA	1:40.83	1:40.38	B1:37.52	1:38.01	1:38.56	D N R	* 5
PETER MARSHALL	38	SAAB 96	1:41.52	1:48.90	1:41.52	1:50.80	B1:38.65	D N R	* 6
KURT WEISS	1	FORD FIESTA	1:41.91	1:42.65	1:41.13	B1:40.23	1:41.66	D N R	* 7
TODD PARO	35	VW SCIROCCO	1:47.87	1:49.58	1:49.89	1:49.58	1:47.89	B1:46.86	* 8

(GM) GREEN MACHINE - 1970 CHEVY 1/4x20 BOLTS-STUDS CLASS - SUNDAY 2-7-1988

* NAME	*NUMB*	CAR	* RUN 1 *	* RUN 2 *	* RUN 3 *	* RUN 4 *	* RUN 5 *	*POS*
WILSON WRIGHT	9	CHEVY WAGON	1:37.05	1:34.69	B1:34.22	1:37.05	* 1T	
MARK MAJCHER	0	CHEVY WAGON	B1:36.53	1:36.58	1:36.73	D N R	* 2T	
PETER NIXON	24	CHEVY WAGON	1:52.36	B1:36.76	1:43.60	1:39.24	* 3T	
GERARD MICHNEY	33	CHEVY WAGON	1:38.09	1:37.19	B1:36.81	D N R	* 4T	
STEVE SPRAGUE	15	CHEVY WAGON	1:37.37	B1:36.99	D N R	D N R	* 5T	
BILL FOSHAY	30	CHEVY WAGON	1:44.96	1:44.33	B1:37.85	D N R	* 6	
KEITH COOPER	36	CHEVY WAGON	1:42.88	2:00.57	B1:37.89	1:42.01	* 7	
DAVE HATHAWAY	21	CHEVY WAGON	B1:39.19	1:39.36	1:40.51	1:42.41	* 8	
BOB MATSON	3	CHEVY WAGON	B1:39.90	1:41.88	1:42.83	1:45.03	* 9	
KEITH MARTENS	18	CHEVY WAGON	1:42.09	B1:40.41	1:46.91	D N R	* 10	
CLARK NICHOLLS	6	CHEVY WAGON	B1:42.09	1:42.26	2:11.05	1:51.88	* 11	
ERIC WEISS	27	CHEVY WAGON	1:43.60	1:44.45	B1:42.25	1:46.45	* 12	
KEVIN NEWELL	39	CHEVY WAGON	1:46.23	1:48.20	B1:44.25	1:44.33	* 13	
ROGER SLOPER	12	CHEVY WAGON	B1:44.64	D N R	D N R	D N R	* 14	



YOU ARE INVITED TO ATTEND THE AREA ONE DINNER

AND THE 28TH ANNUAL

# NARRC AWARDS BANQUET



OF THE NORTH ATLANTIC ROAD RACING CHAMPIONSHIP

HOSTED BY THE MOHAWK-HUDSON REGION

DATE: SATURDAY, MARCH 26, 1988

TIME: 7:00 PM

PLACE: MANERO'S STEAK HOUSE  
559 STEAMBOAT ROAD  
GREENWICH, CONNECTICUT  
203/869-0049

DIRECTIONS: EXIT 3 OFF INTERSTATE 95

From NY, take a right at the end of the ramp, go to the end of the street, take another right and that will be Steamboat Road.

From New Haven, take a left, go to the end of the road, and then right is Steamboat Road.

ACCOMMODATIONS: Showboat Motor Inn: 203/661-9800  
Sheraton Motor Inn: 203/637-3691

MENU INCLUDES: Soup, Salad, Garlic Bread, T-Bone Steak, Baked Potato, French-Fried Onions, Dessert, and Coffee

FOR RESERVATIONS: Make Check Payable to Mohawk-Hudson Region, SCCA

MAIL \$25.00/per person BEFORE MARCH 19TH TO:

Lee Schaller  
127 Forts Ferry Road, Apt. C  
Latham, NY 12110  
518/783-1914

Please include name, address, telephone number, and the number of people in your party.

ICE TRIALS 1988 REPORT

*Clayton Nichols*

At last, the year I've been waiting so long for. Sunny weather, little snow, TWO plows, a smooth lake, no trouble with fishermen or snowmobiles, a car everyone can drive and a record turnout of 33 on Saturday and 44 on Sunday! I'm pleased, even if I was thoroughly trounced in the Green Machine. I guess that about says it all. Thanks to Bill Foshay and Steve Sprague for bringing their plows! It sure was a good feeling to know that area was fully staffed. All those years I just kept my fingers crossed! I don't think even even 5 plows would have been enough if we ran 1 week later!

Just some of the logistics for the event. Coordinate with the Pittsfield Winter Sports Committee - Winter Carnival. Attend meetings every Wednesday night. Arrange for food services admittedly the easiest of all the tasks. Get trophies. Arrange with Jim Garry to have an SCCA Safety Steward, without which we cannot have an event (luckily Keith Martens is a regular entrant!). Arrange for a plow and sweat a lot when I find out Bill Foshay has the engine out of his. Feel euphoric when I find out we will have 2. Design and print entry forms.

For the Green Machine. Arrange for a license plate so we can get it there and back. Arrange to leave it at the lake Saturday night. Get the tires mounted and balanced. Install new water pump, ignition coil and heater core. Install camera mount. Wire up heater fan, cigarette lighter, CB radio. Bleed brakes Friday night when they totally fail Thursday night prior to event. Arrange for generator and air compressor to service leaky tires. Locate gas cans for the beast. We used 50 gallons of gasoline in 2 days. Change engine oil and filter. Thanks to Mark and Wilson for their continued support.

The in-car-camera in the Green Machine made for interesting viewing Saturday and Sunday nights. The remote microphone didn't work, however, on Saturday, so we just used the Camera mike on Sunday. The Saturday video would have been much better if there was sound!

What's the future of the Green Machine? It now resides under more than a foot of snow at Wilson's, (no, he won both days fair and square!) where it will rest during the off-season (more than 360 days a year). There will be a couple of work sessions sometime when it's warm to evaluate the condition of the car and plan just what work is required to improve its performance and reliability. Shock absorbers all around and getting the brakes working all around are on the list if the chassis looks sound enough. There is concern for the necessity of replacing the transmission (turbo-hydromatic 350) which slips occasionally and is the reason the original owner donated the entire car. The starter motor may also require replacement. Any donations? We still seek 15 inch wheels and a set of wide tires for the front. The rears are 255x60x15's.

Mohawk-Hudson Region SCCA

# AUTOSPORT



Quality Imported Parts & Accessories For Enthusiasts

KNOWLEDGEABLE PERSONNEL

HELLA LIGHTS - MANUALS - TOOLS - RECARO SEATS - NOMEX DRIVERS SUITS

RACING ACCESSORIES & MORE

SPECIAL ORDERS WELCOME - WE SHIP UPS DAILY

## 877-7040

(1/4 MILE EAST OF NORTHWAY EXIT 10)

RT 9 & USHERS RD. P.O. BOX 743 CLIFTON PARK NY 12065  
ASK ABOUT OUR PREFERRED CUSTOMER DISCOUNT CARD





\*\*\*\*\*  
 PITTSFIELD WINTER SPORTS COMMITTEE \*  
 MOHAWK HUDSON REGION SCCA \*  
 BERKSHIRE MOTOR SPORTS CLUB \*  
 \*\*\*\*\*

28th ANNUAL ICE TRIALS - 2-6-88 - OFFICIAL RESULTS  
 \*\*\*\*\*  
 SATURDAY  
 \*\*\*\*\*

T NEXT TO POSITION INDICATES A TROPHY WAS AWARDED \*  
 B NEXT TO TIME INDICATES BEST TIME \*  
 FTD NEXT TO POSITION INDICATES FASTEST TIME OF DAY \*  
 D N F INDICATES DID NOT FINISH, PROBABLY BECAME STUCK \*  
 D N R INDICATES DID NOT RUN \*  
 \*\*\*\*\*

\* (4WD) FOUR WHEEL DRIVE UN-STUDDED CLASS - SATURDAY 2-6-1988 \*  
 \*\*\*\*\*

* NAME	*NUMB*	CAR	* RUN 1 *	* RUN 2 *	* RUN 3 *	* RUN 4 *	* RUN 5 *	*POS*
PAUL TICHY	7	FORD RANGER PU	1:45.90	1:44.76	1:41.80	B1:38.17	1:38.54	* 1T
STACY SPRING	26	CHEVY PICKUP	1:41.36	1:40.86	1:38.95	1:41.91	B1:40.30	* 2T
JAMES MARSHALL	10	FORD RANGER PU	1:49.38	1:42.59	1:44.08	1:40.77	B1:39.77	* 3T
JAMES GAGE	22	FORD RANGER PU	1:48.76	1:44.52	1:42.13	B1:40.92	1:42.22	* 4
HAL LINKER	20	CHEVY PICKUP	1:46.51	1:46.43	1:44.59	1:45.53	B1:42.39	* 5
KIM COMRIE	2	FORD RANGER PU	1:53.17	1:45.35	1:47.53	B1:43.89	1:45.22	* 6
BRUCE TAYLOR	16	SAMURAI	1:57.84	1:45.01	2:03.19	1:46.19	B1:44.39	* 7
FRED SCOTT-SMITH	28	PICK UP TRUCK	D N R	B1:46.56	1:47.36	D N R	D N R	* 8
BRIAN BURBANK	23	PICK UP TRUCK	D N R	B2:05.01	D N R	D N R	D N R	* 9

\*\*\*\*\*  
 \* (FRS) FRONT ENGINE REAR DRIVE STUDDED CLASS - SATURDAY 2-6-1988 \*  
 \*\*\*\*\*

KURT WEISS	1	MAZDA 626	1:54.45	1:53.27	1:49.50	B1:44.33	D N F	* 1T
GERARD MICHNEY	31	MAZDA 626	1:49.92	B1:47.25	1:53.43	2:05.96	2:00.10	* 2
TERESA TERRY	29	MAZDA 626	2:11.18	2:23.47	1:59.05	D N R	B1:56.59	* 3

\* (FRM) FRONT ENGINE REAR DRIVE SHEET METAL SCREWS SATURDAY 2-6-1988 \*  
 \*\*\*\*\*

CHRIS HAVAS	14	MERCURY CAPRI	1:40.68	1:39.30	1:38.02	1:36.06	B1:35.06	* 1
RAY BOWDEN	19	MERCURY CAPRI	1:51.50	D N F	1:45.82	B1:37.09	1:45.01	* 2

\* (FF) FRONT ENGINE FRONT DRIVE UNSTUDDED CLASS - SATURDAY 2-6-1988 \*  
 \*\*\*\*\*

KEITH MARTENS	11	CHEVY CITATION	1:48.65	1:42.48	1:43.54	1:41.17	B1:39.80	* 1T
DAN GILMORE	8	FORD FIESTA	1:50.15	1:45.10	1:44.43	1:41.42	B1:40.74	* 2T
BILL FOSHAY	5	FORD FIESTA	1:54.25	1:50.27	1:54.43	1:45.00	B1:41.00	* 3
STEVE SPRAGUE	25	SAAB 9000	1:47.01	B1:44.23	1:44.94	D N R	D N R	* 4
WARREN WETHERELL	32	HONDA CIVIC	1:53.62	1:52.36	1:49.56	1:46.53	B1:44.72	* 5

\* (FFS) FRONT ENGINE FRONT DRIVE STUDDED CLASS - SATURDAY 2-6-1988 \*  
 \*\*\*\*\*

BOB CLAFFIE	17	HONDA CIVIC	1:28.39	1:27.28	1:26.71	1:27.45	B1:25.86	* 1T-FTD
WILSON WRIGHT	4	VW RABBIT	1:34.93	B1:27.29	1:28.80	D N F	1:27.32	* 2
TODD PARO	13	VW SCIROCCO	1:51.24	1:44.72	1:46.27	1:41.83	B1:41.73	* 3

\* (GM) GREEN MACHINE 1970 CHEVY 1/4x20 BOLTS-STUDS CLASS SATURDAY 2-6-1988 \*  
 \*\*\*\*\*

WILSON WRIGHT	9	CHEVY WAGON	D N F	1:32.96	B1:28.34	1:30.24	1:33.40	* 1T
MARK MAJCHER	0	CHEVY WAGON	2:01.97	1:39.90	1:34.95	B1:37.09	1:32.74	* 2T
ROGER SLOPER	12	CHEVY WAGON	1:45.27	1:38.43	B1:33.31	1:51.73	1:37.33	* 3T
KEITH MARTENS	18	CHEVY WAGON	1:43.71	1:40.06	1:36.86	1:49.31	B1:34.85	* 4T
DAVE HATHAWAY	21	CHEVY WAGON	1:43.81	B1:35.24	1:38.30	2:13.79	1:36.14	* 5
STEVE SPRAGUE	15	CHEVY WAGON	1:44.61	1:52.66	B1:35.98	D N R	D N R	* 6
CLARK NICHOLLS	6	CHEVY WAGON	1:42.43	1:42.49	1:41.60	B1:36.03	1:48.35	* 7
BILL FOSHAY	30	CHEVY WAGON	1:37.99	1:36.96	1:37.55	B1:36.66	1:37.86	* 8
PETER NIXON	24	CHEVY WAGON	1:47.41	1:39.68	D N F	1:38.46	B1:37.19	* 9
ERIC WEISS	27	CHEVY WAGON	2:15.68	1:45.37	1:42.37	B1:38.92	1:42.27	* 10
ALTON NICHOLLS	3	CHEVY WAGON	1:58.14	1:46.41	1:51.90	B1:45.25	1:48.35	* 11

Special thanks to Flynn Volkswagen for the loan of the VW Vanagon for housing the timing equipment. Contact Jim LaFrance (finished 4th in the Halloween Rallye) if you are in the market for a new or used Volkswagen, Porsche or Audi.

Also special thanks to my friends, Lloyd and Janice Hughes who provided the (hot) food concession in the pavilion. They are available for your event, too, with 2 portable concession kitchens. Call them at (413)442-1327.

Everyone owes Dave Melle a round of thanks for taking care of all the timing chores on Saturday. Dave is the chairman of the Pittsfield Winter Sports Committee, operating under the Pittsfield Department of Parks and Recreation. Without the help of these organizations, this event would not be possible. Also thanks to Roger Sloper for setting up the timing equipment Sunday and starting us off when Dave was unable to be there.